

DeltaStream Evaporative Cooling



MoffittCorp.com | (800) 474-3267
1351 13th Ave S. Suite 130
Jacksonville Beach, FL 32250



DeltaStream Product Details

PRODUCT DESCRIPTION

The DeltaStream evaporative cooling unit can help lower building temperatures as much as a 30°F below outdoor ambient condition. This self-cleaning, ultra-hygienic system is a more efficient, technologically advanced version of the off-the-shelf evaporative cooler.

It works by using an internal fan to draw outside air across the desorption medium. The water in this medium evaporates and removes sensible energy from the air passing through it. This ensures that fresh, cool air is consistently supplied to the facility in a cost-effective way.

The DeltaStream is designed for commercial and industrial applications to cool outdoor air 10° to 30°F below ambient conditions. It is designed for 16,800 CFM. The direct drive variable speed motors reduce maintenance while increasing efficiency.

STANDARD FEATURES

- Max. Operating Temperatures: -20 °C to +40 °C, -5 °F to 104 °F
- Housing Material: Mill-Finish Aluminum
- Housing Fasteners: Stainless Steel
- Motor: Direct drive variable speed motors
- Medium: High-efficiency cellulose medium
- Tubing: Polypropylene tubing
- Mounting: Roof or ground
- Overall Dimensions: 78" L x 78" W x 65" H
- Curb Dimensions: 48" x 48"
- Curb Cap Dimensions: 48 ¾" x 48 ¾"
- Weight: (excludes curbs & accessories)
 - Downward Discharge: 900 lbs. dry, 1100 lbs. wet
 - Upward Discharge: weight 1100 lbs. dry, 1300 lbs. wet

OPTIONAL FEATURES

- Ducting & fan package
- Maintenance packages available
- Automated Controls
- Building Management System integration

BENEFITS

- Modular system designed to meet a variety of requirements.
- Superior energy savings vs. conventional A.C., 20-30% of the power consumption.
- Uses minimal electricity and water to run.
- Free from refrigerants, environmentally friendly.
- Ultra-hygienic. Parts which encounter water are double powder coated, self-drying, & self-cleaning.
- Integrated water quality system.

INDUSTRY APPLICATIONS

- | | | |
|----------------------|-------------------------|-------------------------|
| • Data Centers | • General Manufacturing | • Warehouse & Storage |
| • Exhibition Halls | • Plastics Industry | • Transformer Buildings |
| • Food & Agriculture | • Pulp & Paper Industry | • +Others |

DeltaStream Evaporative Cooling

DeltaStream Specifications

1. Control Panel
 2. Water circulation pumps
 3. Vertical level sensor
 4. 5 hp motor
 5. Motor mount
 6. Propeller
 7. Spinning
 8. Curb cap
 9. Perforated door
 10. Perforated door, control
 11. Desorption media
 12. Drain assembly
 13. Reservoir
 14. Water distribution system
 15. Lower access door
 16. Solenoid
 17. Upward discharge top
 18. Reservoir cap
 19. Upward discharge motor support
- Not pictured: 30A disconnect*

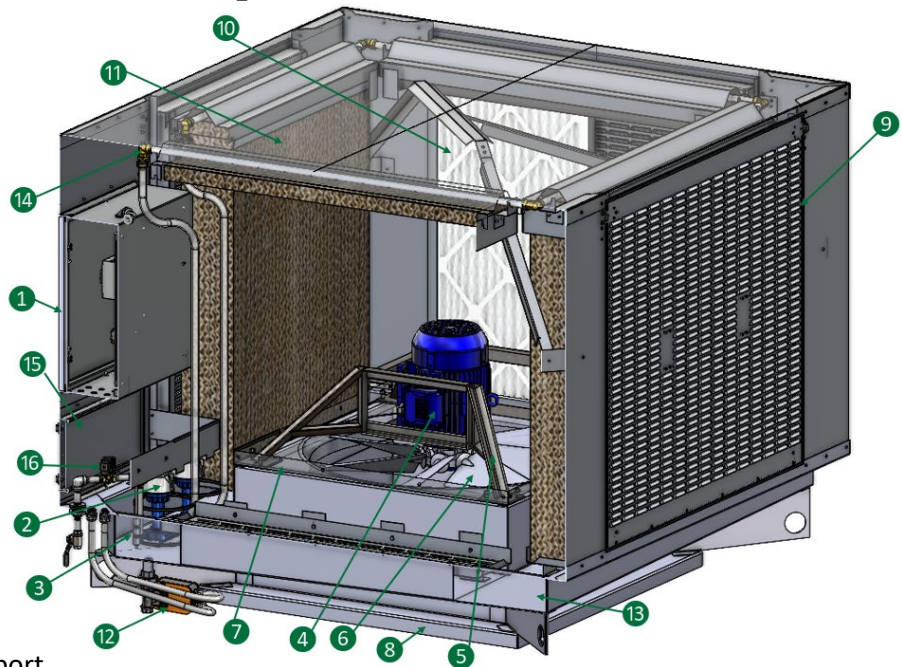

- Overall Dimensions: 78" L x 78" W x 65" H
- Curb Dimensions: 48" x 48"
- Curb Cap Dimensions: 48 3/4" x 48 3/4"
- Weight: (excludes curbs & accessories)
 - Downward Discharge:
 - Dry: 900 lbs., Wet: 1100 lbs.
 - Upward Discharge:
 - Dry: 1100 lbs., Wet: 1300 lbs.
- Filter Quantity: 6 (2 per standard side)
 - Control Size: 2
- Filter Size: 24" x 48", 24" x 36"
- Filter Rating: Merv 8

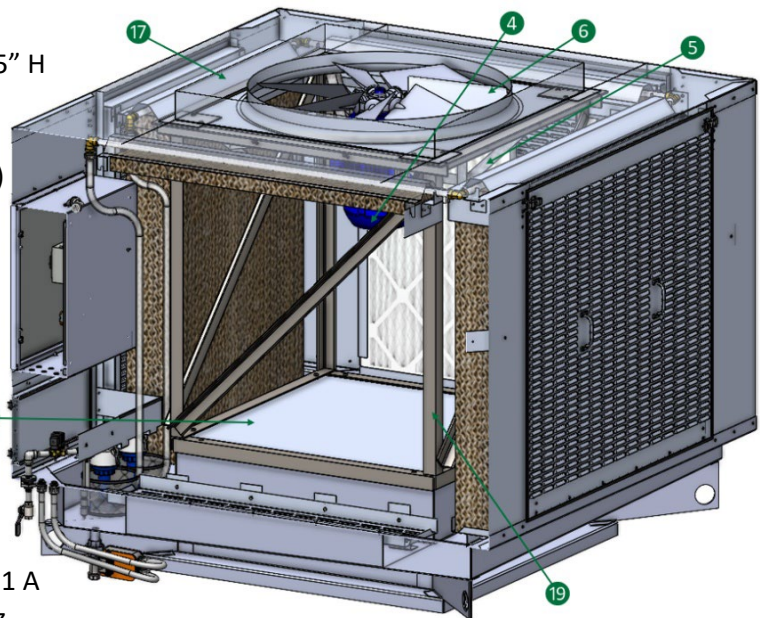

Electrical Data and Controls

- Nominal Output & Current: 5.06 kW, 11 A
- Power supply: 460VAC - 3 Phase, 60 Hz
- Internal Breaker: 20 A
- Type: Central PLC with remote connectivity
- Frequency: 60 Hz
- Amp draw 2.5 A
- Power supply: 120 VAC - 3 Phase, 60 Hz

Nominal Volumetric Flow Rate

- Volumetric flow rate: 16,800 ft³/min
- Nominal external pressure drop: 0.9 in. w.g.
- Maximum external pressure drop: 1.125 In. w.g.

DeltaStream Evaporative Cooling

DeltaStream Damper

The damper is installed within the ducting before the entrance to the building. On a downward discharge DeltaStream system, the damper will be placed between the unit and the ducting, allowing the DeltaStream to sit on top of the flange.

For an upward discharge DeltaStream system, the damper will be orientated horizontally and fastened to the ducting at the building entrance.

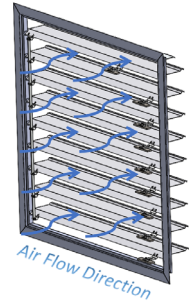

DeltaStream Hygiene

The DeltaStream maintains water and air cleanliness while it provides powerful, sub-ambient cooling. It has been designed and tested to prevent bacterial growth and eliminate contaminants. It is self-cleaning during regular use, and with routine, semi-annual maintenance, will run trouble free for years to come.

Each unit uses 15 standard-sized, desorption media panels. The desorption media is state-of-the art, and designed specifically for evaporative cooling.

The unit empties all water once a day. This allows the piping, reservoir, water channels, and desorption media time to completely dry. Routine system drying prevents bacterial growth and promotes hygienic conditions.

The DeltaStream is a self-cleaning, ultra-hygienic, technologically advanced evaporative cooler.



Desorption Media

DeltaStream Maintenance

DeltaStream evaporative cooling units operate 24 hours a day, 7 days a week, 365 days a year. As a result, Moffitt suggests scheduled, semi-annual maintenance (Spring and Fall) to keep the DeltaStream running smoothly. Our team provides full service with the selection of the maintenance plan. Maintenance includes.



- Checking components
- Cleaning the reservoir, sensors, filters, and piping
- Checking the water supply
- Changing the air filters
- Rinsing the desorption media
- Checking the automated control functions
- Seasonal adjustments

Maintenance must be carried out by qualified, trained personnel. Talk with the Moffitt team to learn more about our maintenance service and how it can be utilized in for our facility.

DeltaStream CFD Modeling

At Moffitt, we utilized Computational Fluid Dynamics (CFD) modeling to show the impact our ventilation solutions will have on your building. Below are some examples of models depicting the power of DeltaStream evaporative cooling units.

Example 1) Comparison of baseline model without any DeltaStream units, models showing the impact of four (4) units, and eight (8) units.

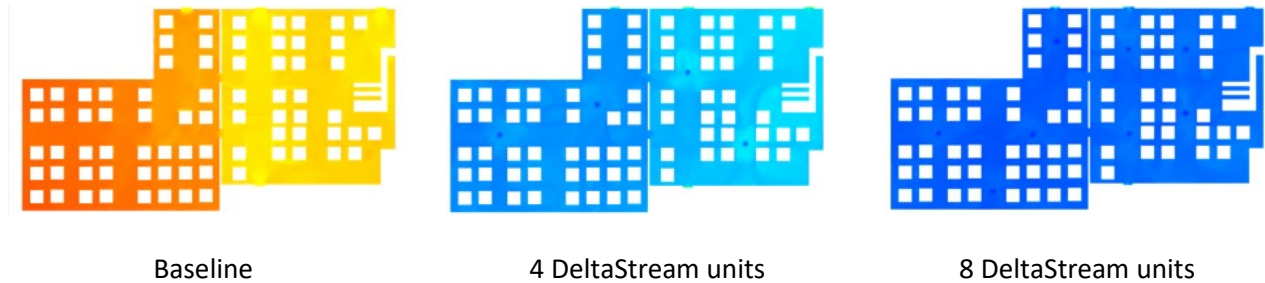

Example 2) A model depicting the air movement from the DeltaStream units installed on the rooftop.

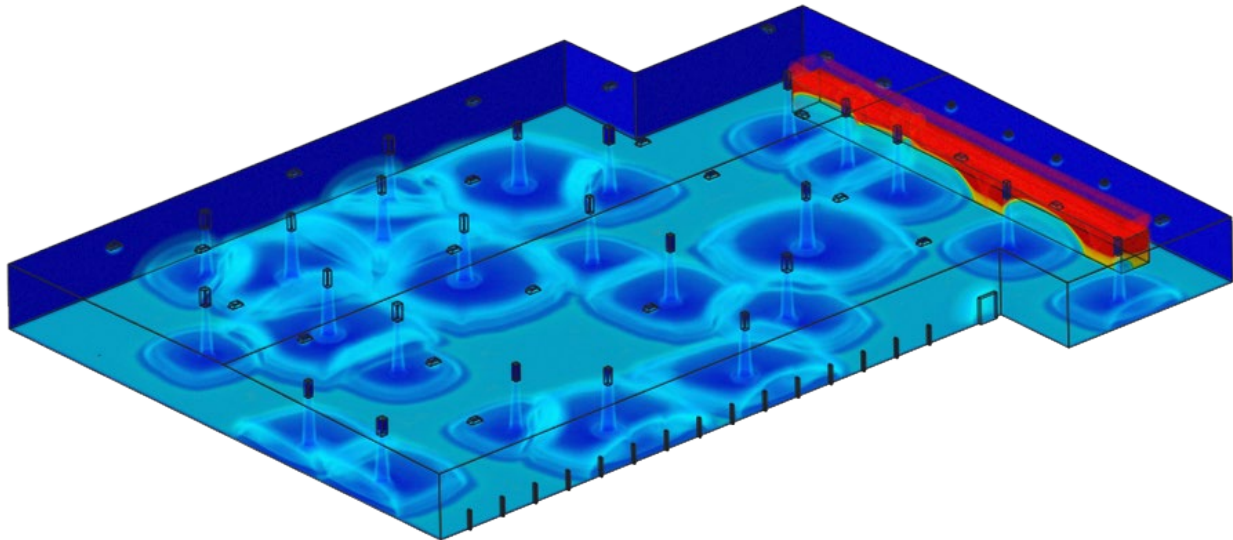

DeltaStream Evaporative Cooling

DeltaStream Mounting

The DeltaStream can be mounted on the rooftop for downward discharge or at the ground level for upward discharge.

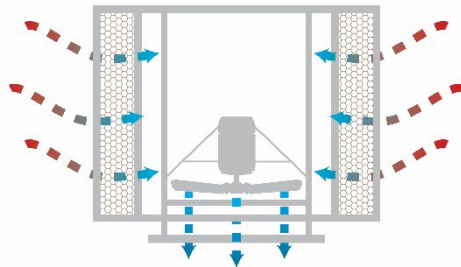

Downward Discharge

The downward configuration DeltaStream unit is normally roof mounted. After the curb is attached to the roof, the duct should be dropped through the curb. The duct should be able to sit on the top flange of the curb, and the damper may be placed on top of it.

When the ducting is installed, the DeltaStream may be lifted and installed onto the curb. Fasten all components as indicated by site installation instructions. This configuration generally uses a duct drop with a 45° elbow, diffuser, or both. These attachments direct the air exactly to where it is most needed.

All ducting should be a minimum of 42" X 42" on the inner surface to ensure proper connection to the DeltaStream unit.

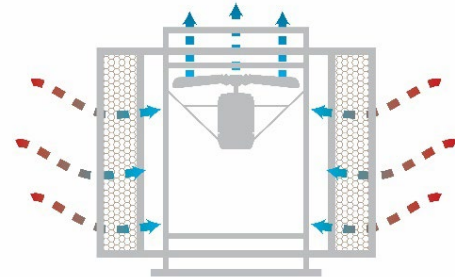

Upward Discharge

The upward configuration will be installed on the ground or solid structure, normally on top of a stand. The unit must be secured to the ground stand before any ducting is attached. No loads may be placed on the DeltaStream top, so ensure that all ducting is supported by another structure or the building itself.

The order of installation should be as follows: stand, DeltaStream unit, ducting and damper at building intake, and then duct connection between unit and ductwork.

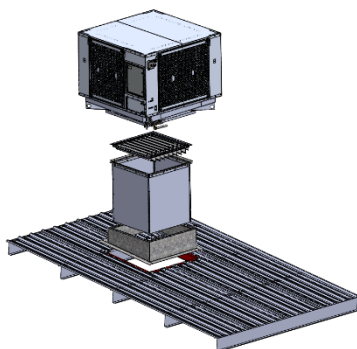

Roof Mounting

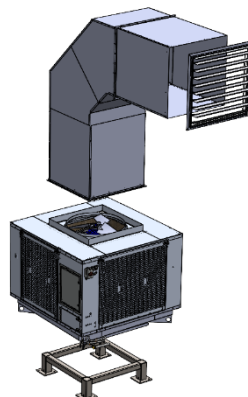

Ground Mounting

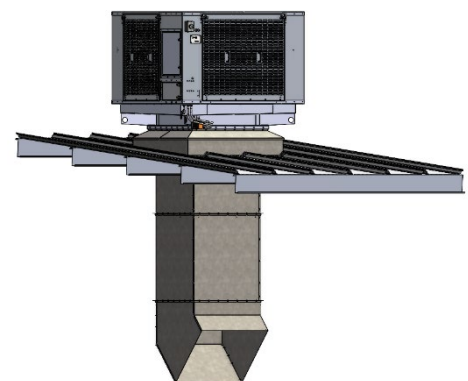

Duct Drop with 45° elbow