



Model P Series

WALL FAN

Model P wall fan brings cool, fresh air into the building. A variety of options for propellers, hoods, and accessories are available.

The Model P uses a direct drive motor.

The Model PB uses a belt drive motor.

PRODUCT BENEFITS

- Supply or exhaust configurations.
- Powerful, reliable motor.
- Direct drive: No belts to replace or pulleys to adjust.
- Belt drive: More precise speed control and quieter operation.
- High-performance dynamically balanced propeller for ideal performance and efficiency.
- Rain hoods prevent water entry:
 - 45 hoods for intake.
 - 90 hoods for exhaust.
- Fans can be combined in powerful, multi-unit configurations.
 - Double unit (Dualstream)
 - Quadruple unit (Quadstream)

HOW IT WORKS

The wall fan blows a powerful blast of cool, fresh air into the building. This intake improves air movement throughout the entire facility.

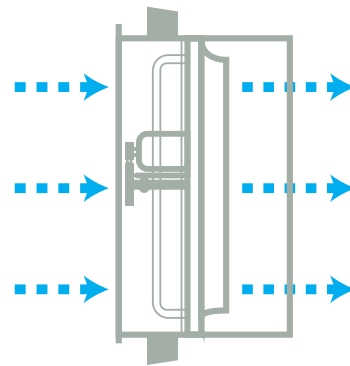

Cool outside air blows into the building.

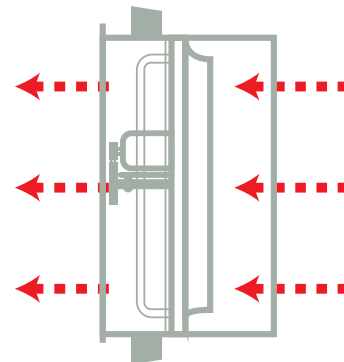

Warm inside air blows out of the building



PRODUCT RANGE

Prop Diameter	Height	Width	Opening	Weight
8" - 72"	8 1/2" - 86 3/8"	7" - 80"	10 3/4" - 86 3/8"	185 lbs - 850 lbs

STANDARD FEATURES

- Heavy-gauge steel construction with bolted connections.
- Heavy-duty TEFC motor with variable pitch drive (direct drive only).
- Direct or belt drive motor configurations.
- Deep spun venturi panel provides superior strength and higher efficiency.
- G90 galvanized steel housing with protective mill finish & flanges for mounting.

OPTIONAL FEATURES

- Wall collar.
- Wall housing.
- Dampers: gravity or motorized.
- Finishes: epoxy, polyurethane, custom.
- Filter box (supply only).
- Guards & screens (bird & insect).
- Reversible propeller.
- Disconnect.
- Weather Hoods
 - 45 (Relief)
 - 90 (Intake)



Scan the QR code for additional product information.
 ©2025 Moffitt. All rights reserved. Vol.1|3/25

