

Model P Direct Drive Fan

SUBMITTAL

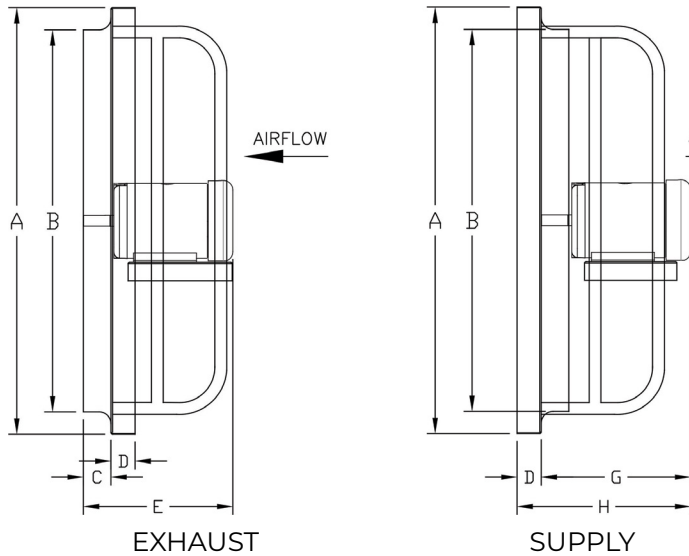

Project Number:
 Project Name:
 Customer:
 Date:

Model: P
 Drive: Direct Drive
 Material: Steel
 Direction:
 Finish:
 Motor:
 Prop:

FAN SIZE	FAN DIMENSIONS (in)							AVERAGE WEIGHT (lbs)
	A	B	C	D	E	G	H	
24	30	25	5	2.75	15.625	16.125	18.875	185
30	36	31	5	2.75	15.75	16.25	19	235
36	42	37	5	2.75	21.25	19	21.75	270
42	48	43	5	2.75	21.75	20.125	22.875	280
48	54	49	5	2.75	26.75	22.625	25.375	376
54	60	55	5.5	2.75	26	25.875	28.625	400
60	66	61	5.5	2.75	26.5	25.875	28.625	415

Specifications for fan size 72 available upon request.

STANDARD FEATURES

- Heavy-gauge steel construction with welded connections.
- High performance propeller.
- Totally Enclosed Fan Cooled (TEFC) motor.
- Direct drive transmission for simplified operation and maximum efficiency.
- Deep spun venturi panel provides superior strength and higher efficiency.
- Standard gray, polyurethane coated exterior.

TAGS	QTY	MODEL	HP	RPM	ELECTRICAL	STATIC PRESSURE	AIRFLOW

NOTES

- Fans may be furnished with factory-installed lifting lugs for quick and efficient installation. Consult the I.O.M. for proper fan hoisting procedures.
- Fans must be installed with remote motor overload protection. Fan motors are not provided with inherent overload or over current protection.
- ⚠ Do not use in hazardous environments where the fan's electrical system could ignite combustible or flammable materials. Units specifically built for hazardous conditions are required for those settings.
- ⚠ Fan guards must be installed when equipment is within reach of the personnel, or within (7) feet of the working level, or when deemed advisable for safety, per OSHA requirements. Guards should be provided by installation personnel when deemed necessary.

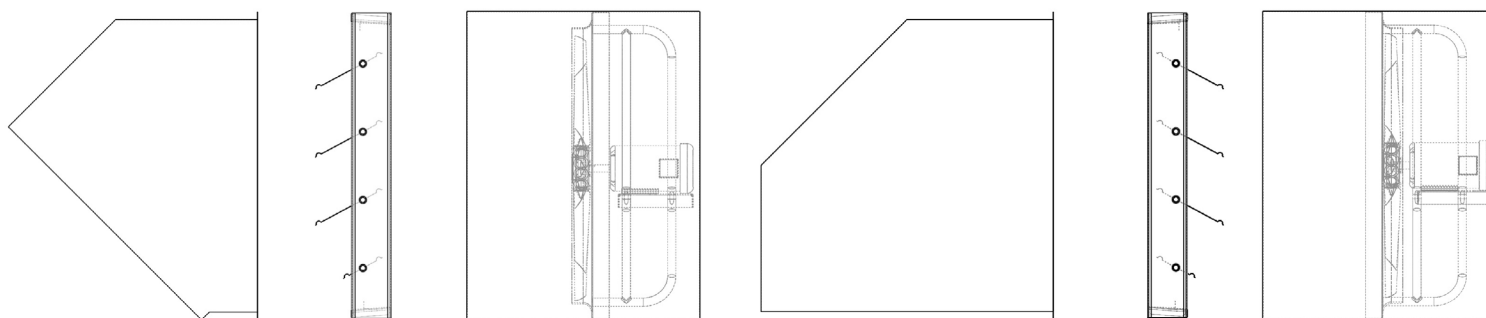

Exhaust Configuration

Supply Configuration

Unit may not include accessories shown above.

OPTIONAL FEATURES

General Accessories

- Wall Collar
- Wall Housing
- Filter Box (Supply Only)
- Inner Guard

Damper

- Gravity Damper Factory Mounted
- Motorized Damper Ships Loose

Disconnect Switch

- NEMA3R Factory Wired
- NEMA4 / 4X Ships Loose

Weather Hood

- 45 Degree Assembled
- 90 Degree Knocked Down (KD)

Installation Accessories

- Knee Braces
- Lifting Lugs
- Outer Guard (bird screen)
- Outer Guard (insect screen)

Additional

- Custom Finish
- UL Listed, UL705
- Other

WARRANTY

Romla Fans guarantees this equipment to be free of defects in material and workmanship under normal use and service for a period of one year from the date of delivery. Romla Fans must be contacted within the one-year period with a warranty claim and the repair authorized by both parties. The location of warranty repairs, either in-field or at the factory, will be at the manufacturer's discretion. This guarantee does not cover any damage caused by neglect of lubrication, accidental overload, or improper installation, nor does it cover the cost of repairs made or attempted outside the factory, with written authorization. Romla Fans only guarantees electric motors to the extent of the motor manufacturer's warranty. Correction of any verified defects by repair or replacement shall constitute fulfillment of this warranty.