

Model SPF Small Direct Drive Fan

SUBMITTAL

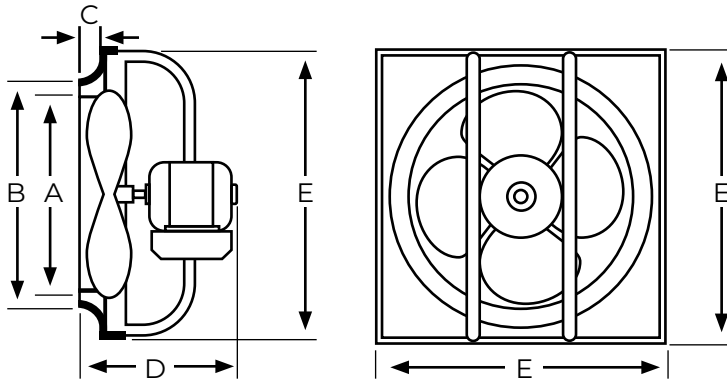

SIDE VIEW

REAR VIEW

Project Number:

Project Name:

Customer:

Date:

Model: SPF

Drive: Direct Drive

Material: Steel

Direction:

Finish:

Motor:

Prop:

FAN SIZE	FAN DIMENSIONS (in)					AVERAGE WEIGHT (lbs)
	A	B	C	D	E	
SPF-8	8	8.5	1	9.5	10.75	11
SPF-10	10	10.5	1	9.5	13.75	14
SPF-12	12	12.5	1	9.75	15	16
SPF-14	14	14.75	1.75	11	18	30
SPF-16	16	16.75	2.5	11.25	20	35
SPF-18	18	18.75	2.5	13.25	22	45
SPF-20	20	20.75	2.75	14.875	24	60

STANDARD FEATURES

- Seamless, single piece fan panel.
- Galvanized steel construction.
- Blade enclosed in protective wire.
- Guard (8, 10, 12 models).
- Motor support on larger sizes.
- Supported by tubular struts welded.
- Deep spun venturi panel provides superior strength and higher efficiency.

TAGS	QTY	MODEL	HP	RPM	ELECTRICAL	STATIC PRESSURE	AIRFLOW

NOTES

- Fans may be furnished with factory-installed lifting lugs for quick and efficient installation. Consult the I.O.M. for proper fan hoisting procedures.
- Fans must be installed with remote motor overload protection. Fan motors are not provided with inherent overload or over current protection.
- ⚠ Do not use in hazardous environments where the fan's electrical system could ignite combustible or flammable materials. Units specifically built for hazardous conditions are required for those settings.
- ⚠ Fan guards must be installed when equipment is within reach of the personnel, or within (7) feet of the working level, or when deemed advisable for safety, per OSHA requirements. Guards should be provided by installation personnel when deemed necessary.

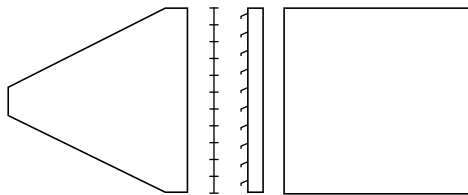

Exhaust Configuration

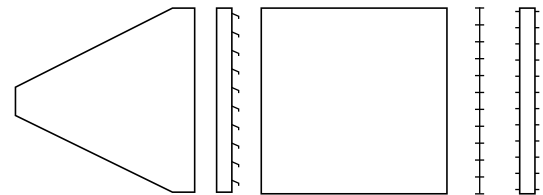

Supply Configuration

Unit may not include accessories shown above.

OPTIONAL FEATURES

General Accessories

- Wall Collar
- Outer Guard (bird screen)
- Outer Guard (insect screen)

Damper

- Gravity Damper
- Motorized Damper
- Factory Mounted
- Ships Loose

Additional

- Custom Finish
- Other

WARRANTY

Romla Fans guarantees this equipment to be free of defects in material and workmanship under normal use and service for a period of one year from the date of delivery. Romla Fans must be contacted within the one-year period with a warranty claim and the repair authorized by both parties. The location of warranty repairs, either in-field or at the factory, will be at the manufacturer's discretion. This guarantee does not cover any damage caused by neglect of lubrication, accidental overload, or improper installation, nor does it cover the cost of repairs made or attempted outside the factory, with written authorization. Romla Fans only guarantees electric motors to the extent of the motor manufacturer's warranty. Correction of any verified defects by repair or replacement shall constitute fulfillment of this warranty.

Moffitt continuously improves our products. Specifications and dimensions are subject to change.

(904) 241-9944 | MoffittCorp.com | ©2025 Moffitt. All rights reserved. Vol.1 | 12/2025